



ANSI E1.4-1 - 2016
Entertainment Technology—
Manual Counterweight Rigging Systems

Approved as an American National Standard by the ANSI Board of Standards Review on 11 October 2016.

Rig/2014-2029r6

© 2016 ESTA. All rights reserved.



Notice and Disclaimer

ESTA does not approve, inspect, or certify any installations, procedures, equipment or materials for compliance with codes, recommended practices or standards. Compliance with an ESTA standard or recommended practice, or an American National Standard developed by ESTA is the sole and exclusive responsibility of the manufacturer or provider and is entirely within their control and discretion. Any markings, identification or other claims of compliance do not constitute certification or approval of any type or nature whatsoever by ESTA.

ESTA neither guarantees nor warrants the accuracy or completeness of any information published herein and disclaim liability for any personal injury, property or other damage or injury of any nature whatsoever, whether special, indirect, consequential or compensatory, directly or indirectly resulting from the publication, use of, or reliance on this document.

In issuing and distributing this document, ESTA does not either (a) undertake to render professional or other services for or on behalf of any person or entity, or (b) undertake any duty to any person or entity with respect to this document or its contents. Anyone using this document should rely on his or her own independent judgment or, as appropriate, seek the advice of a competent professional in determining the exercise of reasonable care in any given circumstance.

Backstagesafety.org

Published by:

ESTA
630 Ninth Avenue, Suite 609
New York, NY 10036 USA
Phone: 1-212-244-1505
Fax: 1-212-244-1502
standards@ESTA.org
<http://www.esta.org/>

ESTA's Technical Standards Program

The ESTA Technical Standards Program was created to serve the ESTA membership and the entertainment industry in technical standards related matters. The goal of the Program is to take a leading role regarding technology within the entertainment industry by creating recommended practices and standards, monitoring standards issues around the world on behalf of our members, and improving communications and safety within the industry. ESTA works closely with the technical standards efforts of other organizations within our industry, including USITT, ESTA, and VPLT, as well as representing the interests of ESTA members to ANSI, UL, and the NFPA. The Technical Standards Program is accredited by the American National Standards Institute.

The Technical Standards Council (TSC) was established by to oversee and coordinate the Technical Standards Program. Made up of individuals experienced in standards-making work from throughout our industry, the Committee approves all projects undertaken and assigns them to the appropriate working group. The Technical Standards Committee employs a Technical Standards Manager to coordinate the work of the Committee and its working groups as well as maintain a “Standards Watch” on behalf of members. Working groups include: Control Protocols, Electrical Power, Floors, Fog and Smoke, Followspot Position, Photometrics, Rigging, and Stage Lifts.

ESTA encourages active participation in the Technical Standards Program. There are several ways to become involved. If you would like to become a member of an existing working group, as have over two hundred people, you must complete an application which is available from the ESTA office. Your application is subject to approval by the working group and you will be required to actively participate in the work of the group. This includes responding to letter ballots and attending meetings. Membership in ESTA is not a requirement. You can also become involved by requesting that the TSC develop a standard or a recommended practice in an area of concern to you.

The Rigging Working Group, which authored this Standard, consists of a cross section of entertainment industry professionals representing a diversity of interests related to rigging and stage machinery for theatrical events. ESTA is committed to developing consensus-based standards and recommended practices in an open setting. Future Rigging Working Group projects will include updating this publication as changes in technology and experience warrant, as well as developing new standards and recommended practices for the benefit of the entertainment industry.

Investors in Innovation

The Technical Standard Program (TSP) is financially supported by companies and individuals who make undirected donations to the TSP. The Investors in Innovation when this standard was approved by ANSI's Board of Standards Review include these companies and individuals:

VISIONARY (\$10,000 & up; >100 employees/members)

Columbus McKinnon
ETC
LDI

ProSight Specialty Insurance
United States Institute for Theatre Technology

VISIONARY (\$5,000 & up; 20–100 employees/members)

Altman Lighting, Inc.

JR Clancy

VISIONARY (\$500 & up; <20 employees/members)

B-Hive Industries, Inc.
Boston Illumination group
Candela Controls Inc.
EGI Event Production Services*
Hughston Engineering Inc.
John T. McGraw

Sapsis Rigging Inc.
Steve Terry
Theatre Projects
Theatre Safety Programs
Steve A. Walker & Associates*
Ralph Weber

INVESTOR (\$3,000–\$9,999; >100 employees/members)

Barbizon Lighting Company
Lex

Rosco Laboratories
Texas Scenic Company

INVESTOR (\$1,500–\$4,999; 20–100 employees/members)

American Society of Theatre Consultants
City Theatrical Inc.

H&H Specialties, Inc.

INVESTOR (\$200–\$499; <20 employees/members)

Tony Giovannetti
Indianapolis Stage Sales & Rentals, Inc.*
LuciTag
Lumenradio AB

Nudelta Digital
Project SSSHH Incorporated
Stephen Vanciel

SUPPORTER (<\$3,000; >100 employees/members)

Ian Foulds, IATSE Local 873
IATSE Local 80

PSAV

SUPPORTER (<\$1,500; 20–100 employees/members)

Blizzard Lighting, LLC
InCord
Lycian Stage Lighting
Oasis Stage Werks

Stage Equipment & Lighting
TOMCAT
Total Structures*
Vincent Lighting Systems*

SUPPORTER (<\$200; <20 employees/members)

Milton Davis
Michael Lay
Niscon Inc.
Skjonberg Controls Inc.

Christopher B. Tilton
Tracy Underhill
Ken Vannice

*Investor for over 15 years

All donations to the TSP support the Technical Standards Program in general and are not directed to or for the benefit of any particular technical standard project or any Working Group working on any particular standard or project. If you would like to help support the Technical Standards Program in its work, please consider becoming an Investor in Innovation by visiting our website at <http://tsp.esta.org/invest> or contacting standards@esta.org.

Contact Information

Technical Standards Manager

Karl G. Ruling
ESTA
630 Ninth Avenue, Suite 609
New York, NY 10036
Phone: 1-212-244-1505
FAX: 1-212-244-1502
standards@ESTA.org

Technical Standards Council Co-Chairs

Mike Garl
[Insert updated information here]
Knoxville, TN 37914
Phone: 1-432-694-7070
FAX: 1-432-689-3805

Mike Wood
Mike Wood Consulting LLC
6401 Clairmont Drive
Austin, TX 78749
Phone: 1-512-288-4916
Fax: 1-866-674-2179

Rigging Working Group Co-chairpersons

Christine Kaiser
Syracuse Scenery & Stage Lighting Co., Inc.
1-315-453-8096
ckaiser@syracusescenery.com

Bill Sapsis
Sapsis Rigging, Inc.
Phone: 1-215-228-0888
bill@sapsis-rigging.com

Rigging Working Group Voting Members

(as of 11 October 2016)

Mike Adamovich; M.G. McLaren, P.C.; G
Jesse Adams; Rose Brand; DR
Tracie Allen; R&M Materials Handling; MP
Frank Allison; M.G. McLaren, P.C.; G
Matthew Antonucci; Contract Services Administration Trust Fund; U
Dana Bartholomew; Foy Invenerprises, Inc.; CP
Scott Battaglia; LMG Inc.; DR
William Beautyman; Limelight Productions, Inc.; DR
Ian Bevan; Walt Disney Company; U
Keith Bohn; Keith Bohn; G
William Bradburn; Aerial Arts, Inc.; U
Bennett Brian; Reed Rigging Inc.; DR
Joseph Champelli; Entertainment Project Services, LLC; DE
Dan Culhane; SECOA; CP

ANSI E1.4-1 - 2016, Entertainment Technology—Manual Counterweight Rigging Systems

Bruce Darden; Rigging Innovators, Inc.; CP
Robert Dean; ZFX Flying Inc.; G
Jonathan Deull; JSD Projects LLC; U
Brad Dittmer; Stage Labor of the Ozarks; U
Russ Dusek; I Weiss; MP
Don Earl; Earl Girls, Inc.; DR
Patrick Finn; Wenger Corp.; CP
Adrian Forbes-Black; Total Structures Inc.; MP
Mike Garl; Mike Garl Consulting LLC; DE
Ethan William Gilson; Advanced Lighting and Production Services; U
Sanford P. Gilzow; Shur-Rig LLC; G
William B. Gorlin; M.G. McLaren, P.C.; G
Jerry Gorrell; Theatre Safety Programs; G
Pat Grenfell; Hoist Sales & Service; DR
Rod Haney; I.A.T.S.E. Local 891; U
Tim Hansen; Oasis Stage Werks; DR
Herb Hart; Columbus McKinnon Corp.; MP
Jeremy Hodgson; Cirque Du Soleil, Inc.; U
Donald Hoffend III; Avista Designs, LLC; G
Joseph Jeremy; Show Distribution Group, Inc.; MP
Ted Jones; Grand Stage; U
Christine L. Kaiser; Syracuse Scenery & Stage Lighting Co., Inc.; DR
Jerald Kraft; JTH Lighting Alliance; CP
Edwin S. Kramer; I.A.T.S.E. Local 1; U
Kyle Kusmer; Steven Schaefer Associates; G
Tom Lapp; Cirque Du Soleil, Inc.; U
Roger Lattin; I.A.T.S.E. Local 728; U
Jon Lenard; Applied Electronics; MP
Michael Lichter; Electronic Theatre Controls, Inc.; MP
Dan Lisowski; University of Wisconsin - Madison; U
Daniel H. Louis; Theta Consulting LLC; G
Joseph McGeough; Foy Invention Enterprises, Inc.; CP
Bob McVay; Schuler Shook; DE
Sam Michael; Thern, Inc.; MP
Steven Michelman; Entertainment Project Services, LLC; DE
Orestes Mihaly; Production Resource Group; DR
Jeff T. Miller; Walt Disney Company; U
Rick Montgomery; R&M Materials Handling; MP
John P. Moore; Hall Associates Flying Effects; CP
Reid Neslage; H & H Specialties Inc.; MP
Jim Niesel; Theatre Projects Consultants, Inc.; DE
Richard J. Nix; ZFX Flying, Inc.; G
Shawn Nolan; Production Resource Group; DR
Tracy Nunnally; Hall Associates Flying Effects; CP
Jennifer O'Leary; Columbus McKinnon Corp.; MP
Kimberly Corbett Oates; Schuler Shook; DE
Carlos Ortega; PSAV Presentation Services; U
Gregory Orth; WNP Services, Inc.; DR
Miriam Paschetto; Geiger Engineers; G
Rocky Paulson; Freeman Companies; DR
Galen Price; Blue Man Group; U
Steven Ricks; Electronic Theatre Controls, Inc.; MP
John Ringelman; Freeman Companies; DR
Heather Rowe; Contract Services Administration Trust Fund; U

ANSI E1.4-1 - 2016, Entertainment Technology—Manual Counterweight Rigging Systems

Bill Sapsis; Sapsis Rigging, Inc.; U
Peter A. Scheu; Scheu Consulting Services, Inc.; DE
Chris Schmidt; Freeman Companies; DR
Joseph S. Schuster; Simpson Gumpertz & Heger; DE
Steven Serafin; Chubb Group of Insurance Companies; G
Harold Ike Shippers; Syracuse Scenery & Stage Lighting Co., Inc.; DR
John C. Snook; Thermotex Industries Inc.; CP
Russell Solomon; Texas Scenic Company; DR
Todd Spencer; PSAV Presentation Services; U
Stephen G. Surratt; Texas Scenic Company; DR
Peter V. Svitavsky; Wenger Corp.; CP
Ken Tilson; Columbus McKinnon Corp.; MP
Will Todd; Milos Group; MP
James Tomlinson; Team Tomlinson; G
Elmer Veith; Total Structures, Inc.; MP
Steve Walker; Steve A. Walker & Associates; G
Charlie Weiner; Milos Group; MP
Michael Wells; Xtreme Structures and Fabrication; MP
Marty Wesstrom; Mountain Productions Inc.; DR
Jeff Wilkowski; Thern, Inc.; MP
Max A. Wilson; Applied Electronics; MP
R. Duane Wilson; Amer. Society of Theatre Consultants; DE
Stephan Jon Wood; Tait Towers Manufacturing LLC; CP
Paul Zagajeski; Wenger Corp.; CP

Rigging Working Group Observer Members

(as of 11 October 2016)

William Ian Auld; Auld Entertainment; U
Robert Barbagallo; Solotech Inc.; DR
Roger Barrett; Star Events Group Ltd.; DR
Roy Bickel; Roy Bickel; G
Scott M. Blair; Full Throttle Films/ VER; DR
Lee J. Bloch; Bloch Design Group, Inc.; G
Louis Bradfield; Louis Bradfield; U
Buddy Braille; North Shore Theatrical Rigging; U
David M. Campbell; Geiger Engineers; G
Daniel J. Clark; Clark-Reder Engineering, Inc.; G
Benjamin Cohen; Chicago Flyhouse Inc.; CP
Jim Digby; Linkin Park Touring/The Collective; U
Tim Franklin; Theta Consulting LLC; G
Tony J. Galuppi; Tony J. Galuppi; U
James M. Garner; Walt Disney Company; G
Chris Geisler; Fluid Design Inc.; DE
Michael P. Gosenski; Rigging Systems LLC; U
Sean Harding; Port Lighting Systems; G
Greg Hareld; Kleege Industries; U
Chris Higgs; Total Solutions Group; G
Jeremy Hochman; Full Throttle Films/ VER; DR
Kent H. Jorgensen; IATSE Local 80; G
Gary Justesen; Oasis Stage Werks; DR
Nevin Kleege; Kleege Industries; U
Wendy Manson; Cirque Du Soleil, Inc.; U
Magali Marcheschi; Polytechnic Montreal; G

ANSI E1.4-1 - 2016, Entertainment Technology—Manual Counterweight Rigging Systems

Bartholomew J. Mueller; Recreation Engineering Inc.; DE
Bob Murphy; Occams Razor Technical Services; G
Edward A. (Ted) Paget; Electronic Theatre Controls, Inc.; MP
Michael Patterson; Pook Diemont & Ohl, Inc.; CP
Kurt Pragman; Pragman Associates, LLC; G
Mark Riddlesperger; LA ProPoint, Inc.; CP
Eric Rouse; Denver Center for the Performing Arts; G
Ford Sellers; Chauvet Lighting; MP
Steven C. Shaw; Levitating Productions, Inc.; MP
Q. Brian Sickels; Q. Brian Sickels; G
Monica Skjonberg; Skjonberg Controls, Inc.; CP
Ross Taylor; Taylor & Taylor Associates; G
Stephen Vanciel; IATSE Local 631; U
Nicholas Gill Wright; I.A.T.S.E. Local 16; G

Interest category codes:

CP = custom-market producer

DR = dealer rental company

MP = mass-market producer

DE = designer

G = general interest

U = user

Backstagesafety.org

Table of Contents

Notice and Disclaimer.....	i
Investors in Innovation.....	iii
Contact Information.....	iv
Foreword.....	ix
Reference standard organizations.....	x
1 Scope.....	1
2 Definitions.....	1
3 Load suspension system requirements.....	5
4 Operating system requirements.....	13
5 Guide system requirements.....	16
6 System documentation, labeling and marking*.....	17
7 Inspections.....	19
8 Design loads and factors.....	20
9 Basic functional and safety requirements.....	22
Figures.....	24
Annex A.....	27

Backstagesafety.org

Foreword

Prior to final approval of ANSI E1.4-2009, no American National Standard had addressed safety of counterweight rigging systems for the entertainment industry. The first documented recognition that safety standards were needed occurred in the early 1960's, when the United States Institute for Theatre Technology (USITT) established its Codes Commission to monitor and report on development of national codes that might be applicable to the entertainment industry. This commission eventually expanded its scope to include the Health & Safety subcommittee. By 1965 USITT had acknowledged that industry standards were necessary to ensure safety in the industry. The first formal, documented effort to accomplish this goal spawned from a Theatre Architecture Commission panel discussion at the 1980 USITT Conference in Kansas City, Missouri. In order to improve the level of safety and to establish a minimum standard for the manufacture of rigging equipment for use in the entertainment industry, the United States Institute for Theatre Technology, Inc. (USITT) established its Rigging and Stage Machinery Standards Committee, with the mission of creating a comprehensive set of standards for this purpose. To further this goal, sub-committees were established to write standards in several areas that combine to achieve a set of standards to fully describe the mechanical equipment used in theatres. This document is an evolution of work first started by separate sub-committees for Manual Counterweight Flying Systems and for Rope and Sandbag Flying Systems. The resulting efforts were combined to form the basis of this document.

It was originally intended that this document be accepted as a standard of USITT and that it ultimately become an American National Standard. In order for the latter to happen, the USITT draft document was turned over to ESTA's Technical Standards Program. It has been further developed by the Rigging Working Group within that program. Members of the Rigging Working Group include appropriately qualified people who represent the broader industry of people who specify, manufacture, sell, and use this equipment, so that all interests are recognized and the standards represent a great depth of knowledge and experience in regards to the equipment.

In 2014, the RWG approved expansion of E1.4's scope into a suite of related standards, all pertaining to manual rigging systems.

This document establishes minimum standards for equipment. However, the proper installation and operation of this equipment are equally important. Equipment should be installed, operated and maintained under the supervision of a competent person. Further, the selection of the proper equipment for any application should be entrusted only to experienced personnel with the proper knowledge and training to recognize and understand all of the hazards and functional requirements involved in the particular installation.

This standard represents equipment manufactured under the constraints of current technology. It is not intended to restrict further developments or enhancements. Future revisions will not imply that previous editions of the standard were inadequate, nor is it the intention of this standard to suggest that equipment manufactured before the creation of this standard is inherently inadequate.

Reference standard organizations

The following standards organizations have developed specific standards documents that may pertain to certain normative requirements of this standard. It is not intended to identify all such organizations, or their respective standards, nor is it intended to imply that compliance with any such standard constitutes an exemption from any legal, jurisdictional, or OSHA-related safety requirements that may exist.

AISI	-	American Iron and Steel Institute, Inc.
ANSI	-	American National Standards Institute
ASME	-	American Society of Mechanical Engineers
ASTM	-	American Society for Testing and Materials
AWS	-	American Welding Society
IFI	-	Industrial Fasteners Institute
ISO	-	International Organization for Standardization
NACM	-	National Association of Chain Manufacturers
ESTA	-	Entertainment Services and Technology Association
SAE	-	Society of Automotive Engineers

Backstagesafety.org

1 Scope

1.1 General

This standard applies to permanently installed, manually operated systems of stage rigging hardware for the raising, lowering, and suspension of scenery, lighting, and similar loads. The systems illustrated in the Figures section describe common arrangements of systems used over performance areas.

1.1.1 System Variations

This standard applies to variations of manual counterweight rigging, including rope and sandbag systems.

1.1.2 Building Structures

This standard applies to rigging hardware and basic functional requirements only, and not to the structure from which it is supported. While not part of this standard, building structural capacity for the intended loads shall be considered in the design and application of rigging systems.

1.2 Annex note references

This document uses annex notes to provide additional reference information about certain specific section requirements, concepts, or intent. Subject matter with a corresponding annex note reference is identified by the asterisk (*) symbol, and the associated reference text is found in the Annex A section, identified with the referring text section number, e.g. an Annex Note to section 3.2 will be identified in the annex section as A.3.2.

1.3 Exclusions

1.3.1 Performer Flying

This standard does not apply to performer flying, or to raising or lowering people.

1.3.2 Powered Rigging

This standard does not apply to any powered equipment used in conjunction with manual counterweight systems. Powered rigging equipment shall conform to the requirements of ANSI E1.6-1, -2, -3, and -4 as applicable to the specific powered rigging equipment and application.

1.4 Intent

The purpose of this standard is to establish minimum performance requirements for manual counterweight rigging systems. This standard establishes a basis for reasonable standards of care, for safety and for general welfare with the intent to minimize hazards associated with Manual Counterweight Rigging Systems.

1.5 Alternative designs

This standard is not intended to prevent alternative designs, materials, or technology. Alternative designs, materials or technology shall comply with the intent of this standard, as deemed applicable by a qualified person.

2 Definitions

2.1 Arbor guide: See **Guide**.

2.2 Arbor pit: An opening in the stage that extends below the stage floor to allow extended travel of counterweight arbors.

2.3 Batten: A pipe, tube, or other singular structural shape that is secured to the lift lines for the purpose of connecting loads to the counterweight system.

2.4 Batten clamp (pipe clamp): A piece of rigging hardware, usually of some rigid material, that wraps or clasps a batten, providing for the attachment of a lift line or other lifting media.

2.5 Belaying pin: A pin inserted into a pin rail hole, used for securing or controlling rope lift lines or spot lines.

2.6 Block: An assembly of one or more sheaves in a housing designed to support one or more lines and allow a change of direction.

2.7 Breaking strength: The load at which failure will occur in a component.

2.8 Bridle: Any suspension configuration in which a lift line is divided into 2 or more tension load path elements angled downward from the lift line termination and connected to the batten.

2.9 Clew: A device, typically a flat steel or aluminum plate with multiple holes, used to connect several lift lines into a single line.

2.10 Compensating system: A component of the counterweight system that automatically adjusts to counterbalance the weight of the lift lines as it shifts between the load side and counterweight side of the head block during operation.

2.11 Competent person: A person who is capable of identifying existing and predictable hazards in the workplace, and who is authorized to take prompt corrective measures to eliminate them.

2.12 Counterweight arbor (counterweight carriage): A guided, movable rigid carriage assembly used to hold counterweights and to counterbalance a load.

2.13 Design factor: A ratio of the design load to the breaking strength of a material or component.

2.14 Design load: The maximum anticipated load that will govern design parameters.

2.15 Double reeve (double purchase): A system using compound reeving of the lift lines and operating line, designed to allow full-height batten travel distance with half the arbor travel distance, but with the requirement that the arbor to be loaded to twice the mass of the batten load.

2.16 Fleet angle: The angle between the centerline of a rope as it enters or exits a sheave groove, and the plane defined by the centerline (pitch) circle of that groove.

2.17 Guide: A device or assembly of devices that connect a counterweight arbor or tension block to the guide rails in order to control the path of its travel.

2.18 Guide rails: A means of guiding the counterweight arbor throughout its travel in the vertical plane, but which also limits horizontal or twisting motions of the arbor. Typical examples are T- or J- shaped members.

2.19 Guide system: Components and assemblies used to vertically guide a counterweight arbor, including components attached to the arbor specifically for such purpose.

2.20 Head block: The stationary block assembly above and closest to the counterweight arbor or pin rail. The head block permits lift lines to change direction. In some counterweight systems, the head block is also grooved to allow the operating line to change direction by 180 degrees.

2.21 Hemp system: See **Rope and sandbag system**

2.22 Idler assembly: An assembly of sheaves and a housing, used to support only the self-weight of the lifting media reeved through it. Idler blocks are used for the same purpose as sag bars except that idlers provide a reduced coefficient of friction.

2.23 Installer: The person or organization that is responsible for the installation of the rigging equipment.

2.24 Lattice track: A wall-mounted guide system, usually for a single arbor, in which the guide rails are located at opposing sides of the arbor assembly, rather than on one side only.

2.25 Lift line: Any fiber or wire rope reeved through block(s) and attached to a load. Lift lines operate singly, as spot lines, or in "sets" of several lift lines working together to support a load.

2.26 Line set: A system of multiple lift lines, operated together to raise, lower, or suspend a load; all of the mechanical, component subsystems required for supporting, positioning, and operating those lift lines as a system.

2.27 Load Suspension system: The battens, blocks, counterbalancing and tension load path, components used to suspend and counterbalance the load.

2.28 Loading bridge (Loading gallery): A load-bearing, elevated personnel access and work area, located to permit counterweight loading and unloading at the arbor.

2.29 Locking collar: A device placed on a counterweight arbor rod to reduce unintended vertical movement of counterweights on the arbor.

2.30 Locking rail: A structural railing that supports the rope locks.

2.31 Loft block: An overhead block through which one or more lift lines pass before being attached to the batten. A loft block typically permits the change of lift line direction in the vertical plane.

2.32 Mule block: A supplementary block located between the head and loft blocks, designed for the specific purpose of changing the direction of lift line travel.

2.33 Operating line: The line that an operator pulls to move, position or hold a counterbalanced load.

2.34 Operating system: Components and assemblies used to move, position and hold the counterbalanced load.

2.35 Out-of-balance condition: A condition where the weight of the batten load differs from the weight of its associated counterweight equipment by more than 23 kg (50 lbs).

2.36 Outrigger batten: A batten mounted in a fixed position parallel to the locking rail, and intended to protect counterweight equipment from unintended contact with non-rigging system elements.

2.37 Pin rail: A rigidly mounted railing, and its associated supports, with holes designed to accept belaying pins, used to tie off rope and sandbag rigging lines. It transfers unbalanced system loads to the building structure.

2.38 Pitch diameter: The diameter of a sheave measured to the centerline of the rope for which it is designed.

2.39 Qualified person: A person who by possession of a recognized degree or certificate of professional standing, or who by extensive knowledge, training, and experience, has successfully demonstrated the ability to solve or resolve problems relating to the subject matter and work.

2.40 Reeve: To pass a rope over the sheaves in a block or a system of blocks.

2.41 Reverse bend: A condition where a rope is reeved in opposing directions, over two or more sheaves, within two lays of the rope strands.

2.42 Rope and sandbag system: A type of counterweight system that uses natural or synthetic rope, instead of wire rope, for the lift lines, and uses sandbags as the counterweight method.

2.43 Rope lock: A positioning device, located on the locking rail that holds an operating line of a balanced counterweight set and prevents unintended movement.

2.44 Sag bar: A linear structural element or other assembly used to support the self-weight of one or more lift lines. A sag bar is used for the same purpose as an idler assembly.

2.45 Sandbag: Fabric bag filled with sand, and used with rope rigging to counterbalance a load.

2.46 Shall: A term used in this standard to indicate that an action is mandatory.

2.47 Should: A term used in this standard to indicate that an action is recommended under most conditions, but is not mandatory.

2.48 Single reeve (single purchase): A system of rigging employing weights, blocks and lines to hold or move a load of similar weight, using a 1:1 mechanical advantage for counterweight and batten load.

2.49 Spot block: A block designed to function as either a head block or loft block in temporary applications, and is also designed to be easily repositioned.

2.50 Spot line: A single line, used in conjunction with one or more spot blocks to support a load.

2.51 Spreader plate: Plate that is installed between counterweight arbor rods to keep the rods from spreading during rapid travel or impact, preventing counterweights from falling out of the arbor.

2.52 Tandem block: A block that consists of a series of single or multiple groove sheaves, each mounted on a separate shaft.

2.53 Tension block: A block designed to remove slack from an operating line, preventing it from twisting in its travel, and from rubbing against wire ropes, structural framing, and adjoining equipment.

2.54 Tension load path: The path of tension-only load that follows the axis of the rope or wire rope lift lines, including all connections and terminations along this path. The single reeve system tension load path includes all connections between the arbor and the batten. The double reeve system tension load path includes all connections between the head block and the batten. The rope and sandbag system tension load path includes all connections between the pin rail and the batten.

2.55 Thimble: A grooved fitting around which a rope is bent to form an eye. It supports and protects the rope to prevent kinking and wear.

2.56 Trim chain: A length of chain and fittings used to connect a lift line to a batten (or other load) and adjust its level relative to the other lift lines along the batten.

2.57 Trim clamp: A device with spring-loaded cams that allows several ropes to be held together and operated as a group.

2.58 Tread diameter: The diameter of a sheave measured at the bottom of its groove.

2.59 Truss batten: Pipes, tubes, or other structural shapes, in which main chord members are connected together with bracing members as a truss, and used in place of a pipe batten.

2.60 Wire guide: Tensioned wire ropes installed and used to guide the path of counterweight arbors or clews.

2.61 Working load limit (WLL): The maximum rated capacity of a component or system during normal operating conditions, as determined by the component manufacturer, or as determined by a qualified person for a specific application.

3 Load suspension system requirements

Line sets in a Manual Counterweight Rigging system shall contain a load suspension system.

3.1 Component requirements

Component assemblies shall be designed, engineered, and manufactured to withstand all design loads without permanent deformation or damage to components and shall comply with the requirements of section 8 Design Factors.

3.1.1 Structural connections

Where load suspension components are connected to building structure, connections shall be designed and approved by a qualified person.

3.1.2 Ductile components required*

Component assemblies, arbors, block housings and mounting components shall be made of materials having ductile properties that will deform plastically without fracturing. The use of materials that are non-ductile shall be permitted only when approved by a qualified person.

3.1.3 Threaded fasteners, minimum material strength

Strength and material requirements for externally-threaded fasteners shall not be less than SAE J429 Grade 5 or ISO R898 Class 8.8 rating. Strength and material properties for internally threaded fasteners shall not be less than SAE J995 Grade 5 rating. Bolts in tension shall have nuts of corresponding grade. Threaded connections of alternative design shall be permitted if they have been approved by a licensed professional engineer.

3.1.3.1 Fastener installation

Fasteners shall be installed in accordance with manufacturer's instructions. Fastening methods shall prevent unintentional loosening.

3.1.3.2 Flat washers required*

Attachments made through slotted or elongated holes, or through holes greater than 1.6mm [1/16 in] over the fastener diameter, shall use flat washers.

3.1.4 Weldments

Welding shall be performed in accordance with AWS standards current at time of manufacture.

3.1.5 Manufacturer's instructions*

Load suspension components shall be installed in accordance with manufacturer's instructions, or as determined by a licensed professional engineer.

3.2 Battens*

3.2.1 Batten loads

Battens shall support the design loads in accordance with the requirements of this standard.

3.2.1.1 Batten design loads

Batten design loads shall be determined by a qualified person. Batten design loads shall not be less than their corresponding maximum counterbalance capacities.

3.2.1.2 Normal design load

Battens shall be designed for a uniformly distributed load of not less than 45 kg/m (30 lbs/ft). The design point load shall not be less than 45 kg (100 pounds), located at mid-span between any two lift lines.

3.2.1.3 Lesser design loads

Battens intended for lower design loads shall be permitted, provided that the batten design, loading and support conditions are approved by a qualified person.

3.2.1.4 Maximum deflection

Maximum deflection for a uniformly distributed load or a concentrated point load shall not exceed 1/180 of the span distance between adjacent lift lines.

3.2.2 Batten splices

The number of splices in a finished batten length shall be minimized to the extent possible. Batten splices shall be constructed in a manner that retains at least the same strength as the unspliced batten material. The use of threaded pipe fittings shall not be permitted as a splicing method.

3.2.3 Protective finish

Battens shall be protected against corrosion.

3.2.4 Visibility markings

A minimum of 100 mm (4 inches) at each end of the batten shall be durably marked with an approved OSHA safety color, except in architecturally sensitive areas.

3.2.5 Batten material strength requirements.

3.2.5.1 Steel battens

Batten material yield (F_y) strength shall not be less than 213,738 kPa [31 ksi]

3.2.5.2 Exception for aluminum battens

Aluminum battens shall be designed in accordance with the *Aluminum Design Manual, 2010 edition*, and shall conform with clause 3.2.1.4 Batten design, maximum deflection.

3.2.6 Truss battens

Truss-battens shall meet the requirements of this standard, except when the truss is constructed of aluminum.

3.2.6.1 Aluminum trusses

Aluminum truss-battens and truss frames shall comply with *ANSI E1.2-2012, Entertainment Technology – Design, Manufacture, and Use of Aluminum Truss and Towers*.

3.2.7 Electrical raceways and plugging strips

3.2.7.1 Not in the load path

Unless specifically designed to carry loads, electrical raceways and plugging strips shall not be considered as a load-bearing component of the load path. Where they are designed to be load-bearing, they shall meet or exceed the design requirements of this section.

3.2.7.2 Part of the connected load

Electrical raceways and plugging strips shall be included as a connected batten load when determining the lineset's capacity.

3.3 Lift line connections.

Lift lines shall be connected at both ends using rated hardware designed for the connection, or using methods approved for use with the lifting media.

3.3.1 Connecting hardware material properties

Shackles, eyebolts, eye nuts, and turnbuckles shall be made of forged steel material.

3.3.2 Batten clamps

3.3.2.1 Strength of materials

Batten clamps shall be made from ductile materials and shall comply with the strength requirements in section 8. Aluminum batten clamps shall be designed in accordance with the Aluminum Design Manual, 2010 edition in addition to the requirements of section 8.

3.3.2.2 Clamping requirements

Batten clamps shall completely encompass the batten circumference, and shall maintain sufficient clamping force to resist rotational loads. The clamp shall permit attachment to the lift line using any hardware connection designed for the connection type, and in a manner that meets the criteria of section 8 Design loads and factors. Batten clamps shall not have sharp edges or corners.

3.3.3 Secure connections

Adjustable or removable connections shall be fixed in position after placement or adjustment. Screw pins in shackles and turnbuckle jaws shall be fixed after pin insertion to prevent loosening.

3.3.4 Trim adjustment

Each lift line shall have a method for slack adjustment and adjusting batten level and trim. Once adjusted, the trim adjustment assembly shall be secured to prevent loosening.

3.3.4.1 Trim chain assemblies*

Trim chain assemblies shall use chain approved by the manufacturer for the application, and shall use rated connection hardware to connect the chain ends to either the batten or to the lift line termination.

3.3.4.1.1 Double load path

The trim chain assembly shall form a double load path from the batten up to the lift line termination, by wrapping not less than 1 1/2 times around the batten. Both load path links of the chain shall be connected to the lift line termination using rated connection hardware or methods. Double load path trim chain assemblies shall have a breaking strength greater than the breaking strength of the wire rope.

3.3.4.1.2 Single load path permitted

Trims chains in a single load path shall be permitted if certified in writing by the chain manufacturer as being suitable for the intended application.

3.3.4.2 Trim clamps

Trim adjustment methods shall not rely solely on friction to maintain tension.

3.3.5 Bridles

Bridle components, attachments, fittings, terminations, and connections shall comply with all relevant requirements of this standard. Bridles shall not be spliced to lift lines.

3.3.5.1 Bridle angles

Bridle leg angles shall not exceed 60-degrees (30-degrees from vertical), or shall be as approved by a qualified person, based upon the specific loading conditions of the application.

3.3.5.2 Bridle connections

Bridle connections at the batten shall be fixed in place to prevent movement along the batten.

3.4 Lift lines

3.4.1 No abrasion

Lift lines shall not contact any part of the building structure, adjacent line sets or other equipment not otherwise intended for contact. A competent person shall determine the method used to prevent such contact.

3.4.2 Splicing not permitted

Lift line splices shall not be permitted.

3.4.3 Reverse bends

In applications where reverse bends are incorporated, the lift line's service life shall be decreased as determined by a qualified person.

3.4.4 Lift line terminations

Lift lines shall be terminated at each end. Use of the termination as a connection shall be permitted.

3.4.4.1 Protection of turnback loops required

Eye or loop terminations formed with a turnback shall use methods to prevent wear of the rope by connected load path elements.

3.4.4.2 Other termination hardware

Termination hardware shall be load rated and sized for the working load limit of the line.

3.4.4.3 Manufacturer's instructions*

Termination hardware shall be installed and used in accordance with the manufacturer's recommendations.

Variations from manufacturer's installation and use recommendations shall be permitted only where requirements for such use are more stringent.

3.4.4.4 Wire rope termination methods*

Wire rope lift lines shall be terminated in accordance with the Wire Rope User Manual, using one of the following methods.

3.4.4.4.1 Swage fittings

Swage-type wire rope fittings shall be selected and applied in accordance with the fitting manufacturer's recommendations, based on the rope material, construction type and environmental considerations.

3.4.4.4.2 Wire rope clip fittings

Wire rope clips shall be made of forged materials. Wire rope clips made of malleable materials shall not be permitted.

3.4.4.5 Natural and synthetic fiber rope termination methods*

Connections for natural-fiber and synthetic ropes shall comply with the requirements of Section 3.3 Lift line connections. Where knots are used for the connection, the entire termination and connection shall maintain the design factors for rope lifting lines as shown in Table 8.2.1, after all derating factors are applied.

3.4.4.6 Natural and synthetic fiber rope terminations without thimbles

Terminations without thimbles shall be permitted for natural fiber and synthetic ropes where the bending diameter of the loop without a thimble is not less than the bending diameter of the loop with a thimble, or where the rope's design load meets the requirements of 3.4.4.5 for knotted connections.

3.5 Block requirements

3.5.1 General

Blocks in the load suspension system shall meet the following general requirements.

3.5.1.1 Line retention*

Lines shall be prevented from unintentionally leaving their grooves.

3.5.1.2 Shafts

Shaft material shall have minimum yield strength (F_y) not less than 310,230 kPa (45 Ksi).

3.5.1.2.1 Shaft support

Shafts shall be supported by the block assembly, and shall be restrained from axial and radial movement in a manner that prevents wear or damage to any block component.

3.5.1.2.2 Shaft bearings

Shaft support methods shall include bearings designed to resist axial and radial loads, as determined by a qualified person according to the block application design criteria. Shaft threads shall be external to the block housing. Shaft threads shall not be subjected to radial or tangential shaft loads.

3.5.1.3 Sheave grooves

Sheave grooves shall be designed to support the rope in accordance with the Wire Rope Users Manual. Grooves on multi-grooved sheaves shall have equal pitch diameters.

3.5.1.4 Mounting

Block assemblies shall include methods for connecting the block to structural framing. Connections shall be adjustable to permit alignment of wire ropes. Nonadjustable fixed connections shall be permitted if periodic adjustment is not required for normal operation. Block mounting shall be designed to prevent block movement and to prevent loosening of the block or its mounting hardware.

3.5.1.4.1 Welding

Welding shall be permitted with the approval of a licensed professional engineer. This attachment method shall only be performed in a manner that permits maintenance or removal of the block.

3.5.1.4.2 Drilling*

Drilling of structural framing, for attachment of a block with bolts, shall be permitted with the approval of a licensed professional engineer.

3.5.1.4.3 Anchors

When attaching blocks to materials requiring anchors, the anchorage method shall be approved by a licensed professional engineer, and shall be installed according to both the manufacturer's recommendations and local code requirements, for the materials into which they are installed.

3.5.1.4.4 Mounting clips*

Mounting clips shall be constructed and sized for the block load and mounting condition. They shall be installed so that the block cannot shift on the support structure. When clips are used to grip a beam flange, the clip shall not yield when the clamp fasteners are tightened to the block manufacturer's recommended torque values.

3.5.1.4.5 Swiveling or pivoting blocks

If the block is designed to swivel (360 degrees) about a pin, or pivot (180 degrees) about a shaft, the mounting shall be designed to accommodate the additional forces in a manner that shall not restrict the free movement of the block.

3.5.1.5 Labels and Marking

Blocks shall be labeled in accordance with Section 6.8.

3.5.2 Loft blocks

Loft blocks shall comply with section 3.5.1 General requirements.

3.5.3 Mule blocks

Mule blocks shall comply with section 3.5.1 General requirements. If field conditions require, the assembly shall be adjustable to maintain fleet angle alignment of the lift lines. Mule block position shall not be supported by lift line tension.

3.5.4 Head blocks

Head blocks shall comply with section 3.5.1 General requirements.

3.5.4.1 Upright blocks

Upright head blocks shall mount to the top side of the structural framing, with the operating and lift lines passing around the sheave and down through the mounting base.

3.5.4.2 Underhung blocks

Underhung head blocks shall mount to the bottom side of the structural framing with the operating and lift lines passing around the sheave below the mounting base.

3.5.4.3 Tandem/Multisheave blocks

Blocks containing more than one sheave shall comply with the requirements of this section, except that multiple shafts to support multiple sheaves shall be permitted. Where multiple shafts are used, no sheave, shaft or bearing component shall interfere with any other such component.

3.5.4.4 Head block location

Head blocks shall be positioned over the arbors so that arbor travel does not impose horizontal forces onto the guide system.

3.5.4.5 Double reeving connections

A double reeve head block shall have a bracket located for attaching the dead ends of the lift line terminations.

3.5.5 Accessories

Accessory attachments to block assemblies shall be permitted, provided that the accessories are specifically designed for the application.

3.5.5.1 Interference not permitted

Accessories shall not interfere with the ropes.

3.5.5.2 Accessory removal

Accessories shall be removable where required to access the sheave, bearings, et cetera for maintenance and repair.

3.5.6 Rope management

Methods for non-load bearing positioning and locating of ropes shall be permitted. Rope management methods shall be required when interference with structure or other system components occurs without rope management methods.

3.5.6.1 Sag bars

Sag bars shall be designed to minimize friction and noise during operation, and shall contain no sharp edges to catch or wear the ropes. Stationary surfaces that are in direct contact with rope shall be replaceable.

3.5.6.2 Sag bar mounting

Where sag bars are provided but are not an integral part of a load-bearing block assembly, they shall be attached to the rigging structural support steel or from the building structural framing.

3.5.6.3 Idler assemblies

Idler assemblies shall be designed to minimize friction and noise during operation, and shall contain no sharp edges to catch or wear the ropes. Idler assemblies shall be placed to maintain alignment of the lift lines with their respective blocks.

3.5.6.4 Idler assembly mounting

Idler assemblies shall be attached to the block housing. Attachment to the rigging structural support steel or to the building structural framing shall be permitted.

3.6 Load suspension system accessories

Non-load bearing accessories shall be permitted in the load suspension system. Non-load bearing accessories shall be required when necessary to prevent misalignment or abrasion, or to maintain compliant fleet angles in the ropes.

3.7 Counterweight arbors

Counterweight arbors shall be designed to hold counterbalance weights in a manner that permits access to, and handling of, the weights.

3.7.1 Attachment points

Counterweight arbors shall be equipped with attachment points for the lift lines and operating lines. The attachment points shall be sized so that terminations do not rest on, pinch, or otherwise bind against adjacent terminations.

3.7.2 Securing weights

Counterweight arbors shall be designed to hold counterweights in a manner that prevents them from dislodging.

3.7.3 Weight distribution

The top face of the counterweight arbor bottom frame shall be configured so that there is a uniformly flat, stable surface on which the counterweights rest. The bottom face of the counterweight shall not bear on any bolt, nut or fastener.

3.7.4 Multiple reeving requirements

Double reeved arbors shall be equipped with sheave assemblies at the top and bottom of the counterweight arbor. Arbor sheave assemblies shall meet the requirements for head blocks or loft blocks as applicable to the number and type(s) of ropes they must accommodate.

3.7.5 Labeling

Counterweight arbors shall be labeled in accordance with Section 6.7 Labeling.

3.7.6 Guide connection methods required

The arbor frame assembly shall connect to the guide system in a manner that permits compliance with Section 5, Guide system requirements.

3.7.7 Standardized configuration*

Where arbor designs contain rods as part of the primary support structure, they shall meet the following criteria:

3.7.7.1 Rod strength

Rod yield strength shall not be less than 248 MPa (36 ksi).

3.7.7.2 Rod Spacing

Rods shall be spaced 25 cm (10 inches) on center.

3.7.7.3 Spreader plates required

Spreader plates that slide freely up and down on the arbor rods shall be permanently installed between the arbor top and bottom plates, and shall be designed to prevent arbor rods from spreading apart under impact. One spreader plate shall be provided for each 600 mm (24 inches) of arbor height, or fraction thereof.

3.7.7.4 Locking collars required

The counterweight arbor shall be equipped with at least one locking collar per arbor rod, each located above the top spreader plate. No tools shall be required to tighten or loosen the locking collar fastening hardware.

3.8 Counterweights*

Counterweights shall be made of materials that will withstand the anticipated service without fracturing.”

3.8.1 Size and shape requirements*

Counterweights shall be shaped in a manner to prevent the weights from accidentally disengaging from the arbor. Counterweights shall be of dimensions and shapes that can be handled by an average person, shall vary in each individual weight size by no more than 3 mm (1/8 inch), and shall be free from sharp edges. Individual counterweights shall not weigh more than 13.6 kg (30 lbs).

3.8.2 Exceptions permitted

Counterweights that are not subject to relocation during normal use shall be exempt from the size and weight limitations.

3.9 Compensating systems*

Compensating systems shall be used when normal operation of the lineset between its limits creates an out-of-balance condition.

3.10 Sandbag counterweights

Sandbag counterweights shall be used only in rope and sandbag systems. Sandbags shall not be used as counterweight for arbor systems.

3.10.1 Sandbags, weight restrictions

Sandbag capacity shall not exceed 136 kg (300 Lbs).

3.10.2 Material strength

Sandbag material and fabrication methods shall be abrasion-resistant and shall resist tears and rupture.

3.10.3 Sandbag connection requirements

The method used to suspend the loaded sandbag shall be load-rated. Hooks shall contain a safety catch.

3.11 Trim clamps

The use of trim clamps on rope and sandbag systems shall be permitted. Where used, trim clamps shall be attached to the lifting lines between the head block and the pin rail. They shall be rated to support the maximum anticipated load of sandbags, taking into account the same design factors as described for lifting lines in section 8 Design loads and factors.

3.12 Pin rails

Rope and sandbag systems shall include a pin rail or equivalent securing method for tension load path rope termination.

3.12.1 Pin rail design loads

The pin rail design load in any direction shall not be less than either a uniformly distributed load of 749 kg per linear meter (500 pounds per linear foot), or a point load of 455 kg (1000 pounds) at the midpoint between the largest span between pin rail supports, whichever is greater. Other design load criteria shall be permitted if

determined by a qualified person and provided that such information is clearly detailed in the system manual (refer to section 6.9 Manuals).

3.12.1.1 Strength and deflection requirements

3.12.1.1.1 Steel pin rails

Deflection and strength requirements for pin rails shall comply with the AISC Steel Construction Manual, current edition.

3.12.1.1.2 Alternative materials

Use of materials other than steel shall be permitted when the design loading, strength and deflection criteria have been evaluated by a qualified person.

3.12.2 Placement

Where necessary to the function of a rigging system, pin rails shall be located to permit the fleet angles as required by section 8 Design factors, and to provide horizontal clearances for any sandbags that may be attached to the lift lines. Pin rail location(s) shall not interfere with any other operational system element.

3.12.3 Shapes

Pin rail cross-sections shall be round or substantially round. Other shapes shall be permitted if all edges are radiused to a dimension equal to or greater than the rope diameter.

3.12.4 Operational requirements

The pin rail shall be drilled through vertically at regular intervals to accommodate either steel or hardwood belaying pins to which the lifting lines are tied. Belaying pins shall be sized to secure all anticipated loads. Fixed (permanently attached to the pin rail) or loose (removable from the pin rail) belaying pins shall be permitted. Pins shall be of cross-sectional shapes and material finishes that do not damage the rope.

3.12.5 Labeling

Pin rails shall be labeled in accordance with section 5.4 Pin rails.

4 Operating system requirements

Line sets in a Manual Counterweight Rigging system shall contain an operating system. Operating systems for counterweight line sets shall include an operating line, an operating line tension adjustment method, and a rope lock.

4.1 Operating system exceptions

4.1.1 Operating systems for rope and sandbag systems shall not require tension blocks or rope locks. Pin rails or equivalent securing methods shall be required for rope and sandbag systems, and shall comply with the requirements for load suspension systems.

4.1.2 Operating line tension adjustment devices shall not be required for line sets using rope material with an operational stretch of less than 5% of its overall length, or where a qualified person deems appropriate.

4.2 Locking rails

Locking rails shall be designed to withstand either the anticipated loads imposed by the counterweight sets, or 23 kg (50 pounds) per rope lock plus concentrated loads of 227 kg (500 pounds) at the midpoint between each locking rail upright, whichever is greater.

4.2.1 Horizontal loads

Locking rails shall be designed to absorb a horizontal load as dictated by system design and applicable codes.

4.2.2 Attachments and anchorages

Locking rails shall be attached to the building structure using welds, bolts or anchors specifically sized and designed for the loads, mounting surfaces, and conditions.

4.2.3 Nonstandard loading conditions

Where locking rails are specifically intended to provide support for non-standard system components, or intended to resist non-vertical loads, the locking rail shall be designed to accommodate all such intended loads.

4.2.4 Rope lock alignment

Locking rails shall permit attachment of rope locks such that the lock maintains alignment of the operating line in accordance with section 4.3.1 Positioning and attachment.

4.3 Rope locks

Housings shall be made of a material having ductile properties that will deform plastically without fracturing. Attachment of the lock to the rail shall transfer loads directly to the rail structure.

4.3.1 Positioning and attachment

Rope locks shall be positioned to impose minimal wear on the operating line as it passes through the system.

4.3.2 Welds not permitted

Rope locks shall not be welded to the locking rail.

4.3.3 Reliable locking mechanism

Rope locks shall remain clamped onto the operating line until intentionally released. Rope locks shall contain means for adjusting clamping force, to compensate for worn ropes or ropes of differing diameters. Rope locks shall have an integral mechanism designed to prevent accidental release.

4.3.4 Capacity

A rope lock shall sustain an out of balance condition of 23 kg (50 pounds).

4.4 Operating lines

4.4.1 Material

Operating lines shall be selected for their intended application and shall conform to section 8 Design loads and factors, Table 8.2.1.

4.4.2 Minimum rope diameter*

The minimum nominal diameter of operating lines shall be no less than 19 mm (3/4 inch).

4.4.3 Reeving

The operating line shall be installed so that it freely runs through the blocks. The operating line shall not abrade against any part of the building structure, adjacent line sets or other equipment. A competent person shall determine the method used to prevent such contact.

Rope lock exception: Abrasion against rope lock jaws shall be permitted.

4.4.4 Operating line termination

Operating line terminations shall not slip under load, shall be adjustable when desired, and shall protect the operating line from damage.

4.4.4.1 The operating line for single reeved systems shall terminate at the arbor top and bottom in a manner that is specifically designed for that purpose.

4.4.4.2 The operating line for double reeved systems shall terminate at the head block, at a point below the arbor travel, and to components specifically designed for that purpose.

4.4.4.3 The operating line shall be terminated with a knot or splice that maintains a minimum 60% of the rope's tensile strength.

4.4.4.3.1 The ends of the operating line shall be finished in a manner that prevents loosening of the termination, and shall be done in accordance with the rope manufacturer's recommendations.

4.4.4.3.2 The operating line termination shall not interfere with adjacent equipment

4.4.4.4 Natural fiber operating lines shall be protected from abrasion and excessive bending stress at the termination by an oval or round thimble of the same size as the rope.

4.4.4.5 The ends of the operating line shall be finished in a manner that prevents fraying or unraveling of the rope ends.

4.5 Operating line tensioning methods*

Operating systems shall have a method to adjust tension in the operating line where the operating line is a closed-loop system.

4.5.1 Tension blocks, general

Where used as an operating system component, tension blocks shall be mounted in a manner that prevents interference between the operating line and any other system or structural element. Tension blocks shall maintain an amount of tension on the operating line not less than the block self-weight. Tension block sheave grooves shall be sized for the operating line diameter.

4.5.2 Tension block mounting and adjustability

Direct attachment to the guide system shall be permitted. The attachment method shall prevent the tension block from releasing when the counterweight set is operated, but shall also permit readjustment of tension when so intended. Tension block mountings shall permit adjustment of tension without the use of tools.

4.5.3 Lubrication

Lubrication shall not be used on tension block mounting components, unless those components have been specifically designed to be lubricated.

4.6 Operational travel limits

Operating systems shall include a method to limit arbor travel to the system's design intent.

4.6.1 Arbor stops*

Stop battens or bars shall be attached where they will provide a stop for the arbors at their designated upper and lower limits of travel, and shall be structurally attached in locations that prevent interference by the arbor or stop, with any other component of the system. The bottom stop shall be located above the level of the tension blocks and shall be capable of supporting the mass of a fully loaded arbor, plus an additional 23 kg [50 lbs] of allowable load imbalance. The top stop shall be capable of resisting the mass of a batten when loaded to the capacity of its arbor, plus an additional 23 kg (50 lbs) of allowable load imbalance. Bumpers shall be bolted to the impact face of both stop assemblies, or shall be permitted to attach to the top and bottom of the arbor assembly. Arbor stops shall be protected from damage due to normal use conditions.

4.6.2 Guide wire stops*

Arbor stops for wire rope guide systems shall not be attached to the wire guides, with the exception that arbor stop attachment to guide wires shall be permitted if the stop slips at loads exceeding 23 kg [50 lbs].

4.7 Outrigger batten

The outrigger batten, when used, shall be mounted so it does not interfere with the movement of operating lines, or other building equipment. The batten shall be rigidly mounted. Connection to the guide system or to the building structure shall be permitted.

5 Guide system requirements

The counterbalancing portions of line sets in a Manual Counterweight Rigging system shall be guided so that non-vertical movement is limited.

5.1 Guide system components

Guide systems shall include vertical guide rails or guide wires and at least one guide. Together, they shall permit vertical movement of the arbor between its upper and lower stops, while limiting horizontal deviations in the arbor's vertical travel.

5.1.1 Adjacent arbor interference

Guide methods shall prevent interference with adjacent lineset components. The minimum spacing between adjacent arbors shall be such that they cannot come into contact with each other under normal operating conditions.

5.1.2 Guide system exceptions

Rope and sand bag systems shall not require a guide system.

5.2 Guide methods

Arbors shall be vertically guided using any method that permits vertical travel and limits lateral movement between the guide (rail) and its associated arbor guide connecting method.

5.2.1 Rigid guide rails

Rigid guide rail systems shall be vertically supported, and rigidly fastened to horizontal supports spaced to prevent deflection of the guide rails during normal operation. Guide rail supports shall be rigidly attached to the building structure so that the guide rails cannot move in any direction. Guide rail supports shall also be equipped with bracing where required to maintain rigidity of the guide system. The bottom support shall be bolted or anchored to the floor using anchorages specifically designed for the loads, mounting surface and conditions. Guide rails shall be installed straight and plumb.

5.2.1.1 Guide rail splices

Where splices are required, they shall be finished in a manner that provides smooth transition between the abutted edges, without offset, warping or twisting of the rails.

5.2.1.2 Guide tolerance

Guides shall limit side-to-side movement to not more than 3mm [1/8"].

5.2.2 Lattice tracks

Guide assemblies shall be mounted on the sides of the arbor so that the arbor is held between two guide rails. Guide rails shall be installed straight and plumb. Guide rail brackets shall insure that the tracks remain parallel and prevent binding or release of the arbor over the length of its travel. Guide rails shall be rigidly attached to the building structure to prevent deflection of the guide rails during normal operation. Arbor stops shall be installed at each end of the track. The stops shall be designed so they do not bind or abrade the operating line.

5.2.3 Wire guide methods

Guide systems using wire ropes as the vertical guide shall only use wire ropes sized to withstand the intended tension and sway loads. Guide wires shall be installed plumb, in equally spaced pairs, on the centerlines of the arbor guides.

5.2.3.1 Guide wire attachments

Guide wire attachments shall be located to permit vertical arbor travel without deflection of the wire rope guides. Guide wire attachment points shall be designed to accept the loads imposed by both tension in the guide wires and sway of the arbors. A licensed professional engineer shall evaluate anticipated guide wire loads to the existing structure.

5.2.3.2 Minimum number required

There shall be a minimum of one guide wire passing through the top and bottom of each end of each arbor, and the guide wires shall be installed plumb. Guide wire terminations and connections shall be designed to withstand anticipated loads. A load rated tension adjustment device shall be incorporated into the assembly, and shall be fixed in position after final adjustments are made. Arbor stops, if used, shall not impart additional load to the wire guides or their respective terminations, and shall slip under load.

5.3 Coefficients of friction

The unlubricated kinetic coefficient of friction between guide rails or wires and their respective arbor guides shall be less than 0.25.

5.4 Lubrication

Lubrication of the guide system shall not be permitted unless specifically recommended by the manufacturer, and lubrication shall only be applied in accordance with the manufacturer's recommendations.

6 System documentation, labeling and marking*

6.1 General requirements

Labeling and signage shall comply with the requirements of the following recognized national standards, where such requirements can be implemented with rigging components, assemblies, and systems:

- *ANSI/NEMA Z535.1-2006 (R2011), Safety Colors*
- *ANSI/NEMA Z535.2-2011, Environmental and Facility Safety Signs*
- *ANSI/NEMA Z535.3-2011, Criteria for Safety Symbols*
- *ANSI/NEMA Z535.4-2011, Product Safety Signs and Labels*
- *ANSI/NEMA Z535.6-2011, Product safety information in product manuals, instructions, and other collateral materials*

6.1.1 Language

Signs and labels shall be in English. In addition to English, other languages shall be permitted.

6.2 Capacities and sizes

The working load limit, manufacturer's name, or grade reference mark shall be permanently displayed on each piece of equipment and hardware. Chain, rope and wire rope shall be exempt from this requirement. If the hardware or equipment is size-specific (e.g. wire rope clips), then the size shall be displayed on the product. Where permanent labeling or marking of individual components is impractical, then the load, manufacturer, or grade reference information shall be indicated in the system reference documents as required in section 6.9 Manuals.

6.3 Locking rails*

All locking rails shall have an individual, permanently applied number or name displayed at each rope lock. Provisions shall be made for the temporary display of secondary descriptions.

6.3.1 Loading and operation signage

Signage shall be displayed at each locking rail stating the capacity of the line sets, electrics, bridges, or other equipment controlled from that position.

6.3.2 Wire-Guided arbors

Locking rails used with wire-guided arbors shall have a sign displayed that warns against excessive tension in the wire guides.

6.4 Pin rails

A sign shall be displayed at each pin rail stating the capacity of line sets and for individual spot lines controlled from the pin rail.

6.5 Operating/loading bridges

Operating and loading bridges shall have a sign stating permissible counterweight storage parameters and limits in kilograms per square meter (pounds per square foot). The mass and size of each unique counterweight type provided in the system shall also be included. A licensed professional engineer shall determine the stated parameters, or the sign shall clearly state "**CAPACITY UNKNOWN.**"

6.5.1 Counterweight stacking hazards

Signage shall include a warning against these hazards, as applicable to the bridge use parameters:

6.5.1.1 Stacking along any open or unprotected edges.

6.5.1.2 Stacking higher than the toe plate height.

6.5.1.3 Stacking along protected edges where the vertical barrier does not extend down to the bridge walking/working surface.

6.5.1.4 Stacking where a trip hazard is created.

6.6 Battens

Each batten shall be marked and labeled with its set number, stage centerline, and lift line locations using the same terminology as that used on the locking rail.

6.7 Counterweight arbors

Arbors using pairs of rods to connect the arbor top and bottom shall have a sign affixed to the back plate at 0.6 meter (2-foot) intervals stating "**CAUTION: Locate spreader plate here.**" Systems using wire guide type arbors shall have readily visible signs stating that spreader plates shall be located at 0.6 meter (2-foot) nominal intervals.

6.7.1 Arbor Capacity

Arbor capacity shall be clearly marked on a flat surface visible to the operator and loader.

6.7.2 Arbor set marking

The number or name of the set shall be located on the arbor, using the same terminology as that used on the locking rail.

6.7.3 Labeling of alternative designs

Arbors of alternate construction shall be labeled with safety and locking procedures relevant to the product.

6.8 Block labeling*

Labeling of head blocks, floor blocks and loft blocks shall be considered as a useful method of correlating them with their respective lineset numbers, using the same terminology as that used for the locking rail.

6.8.1 Head block labeling

Attachment of the label to structure adjacent to the headblock shall be permitted where visibility of the label is improved by doing so.

6.8.2 Loft block labeling

Labeling of every loft block shall not be required where one up-to-downstage row of loft blocks is labeled.

6.8.3 Mule blocks

Mule blocks that divert cables greater than 20 degrees shall be labeled with the set number using the same terminology as that used on the locking rail.

6.9 Lubrication

Any equipment requiring lubrication shall be identified in the maintenance manual stating quantity, type of lubricant, and frequency of lubrication. Lubrication points shall be clearly indicated. Lubrication points shall be accessible without disassembly of the component.

6.10 Manuals*

All rigging installations shall include an operations and maintenance manual ("system manual") for the system. All unique elements of the particular system shall be identified and documented.

6.10.1 Record drawings

System manuals shall include record drawings accurately depicting the installed system. Record drawings shall include component sizes, quantities, types, orientation and relation to other system components.

6.10.2 Maintenance requirements

System manuals shall include applicable maintenance requirements, servicing guidelines, and a listing of component working load limits.

6.10.3 Inspection criteria

Manuals shall include Section 7 inspection processes and results.

6.10.4 Maintenance logs

System manuals shall include a supplemental maintenance log providing a place to record inspections, modifications and repairs to the system, and identifying the person(s) performing such actions.

6.10.5 Manuals accessible

System manuals shall be kept onsite, and shall be made available upon request. The operations portion of the system manual shall be readily accessible to all users of the system.

6.11 General Signage

A sign shall be posted in a prominent, easily accessible location providing the name, address and phone number of the primary system contractor, manufacturer, and supplier (if not already listed) of the system equipment.

7 Inspections

7.1 Prerequisites for initial system acceptance

Minimum inspection and testing requirements of this section are established for initial system acceptance by the following prerequisites:

7.1.1 Lineset components are manufactured under controlled process environments, and to engineered designs;

7.1.2 Lineset components are installed under conditions where a qualified person evaluates system design;

7.1.3 Lineset component manufacturers provide detailed recommendations for the application and installation of their respective products;

7.2 General requirements*

All installations shall be visually inspected, and shall be tested for operation in a non-destructive manner. Qualified persons shall oversee the inspection and testing process, and shall certify that all inspection requirements have been met.

7.2.1 Initial Inspection

All systems shall be inspected after installation and prior to first use. Inspections shall meet the requirements of this section, but additional requirements shall be permitted.

7.2.1.1 Proof testing

Any lineset not meeting the prerequisite requirements of 7.1 above shall be tested by applying a controlled static test load of not less than the design load.

7.2.1.2 Test documentation

The testing supervisor, the installer and the system owner shall retain complete copies of the test documentation.

7.2.2 Regular inspections

Installed rigging systems shall be inspected annually, or more frequently as determined by a qualified person.

7.2.2.1 Manufacturer's recommendations

Inspections shall be performed in accordance with the manufacturer's recommendations and any applicable local code requirements.

7.2.2.2 Inspection documentation

Inspection procedures and results shall be fully documented and the inspection documentation shall be retained by the owner.

8 Design loads and factors

8.1 Recognized codes and standards

All equipment shall be designed, manufactured and installed in compliance with the requirements of this standard and of any applicable jurisdictional code or regulation, where the requirements of such are more stringent.

8.2 Design factors

A qualified person shall determine or approve design factors for all equipment not included in the tension load path. Unless modified by other sections of this document, other codes listed, or governing bodies with jurisdiction over a particular facility, the factors listed in Table 1 shall be used as a minimum performance guideline for tension load path equipment, unless a licensed professional engineer determines that lower values are permitted.

TABLE 1 – Tension Load Path Component design factors

ITEM	MINIMUM DESIGN FACTOR / SIZE
Wire rope	8:1, versus minimum breaking strength as reported by the manufacturer
Sheave diameter	As recommended by rope or wire rope manufacturer*
Maximum fleet angle	1.5 degrees (maximum), or per manufacturer's specific recommendation(s)
Terminating hardware	5:1, or not exceeding published WLL, whichever is more restrictive
Operating lines	Minimum tensile strength of 21,600 N (4,860 pounds), when new
Trim chain assembly	5:1, or not exceeding published WLL, whichever is more restrictive
Batten clamps	5:1, or not exceeding published WLL, whichever is more restrictive

Fiber Rope lifting lines	10:1 [16 mm (5/8 inch) minimum diameter]
--------------------------	--

8.3 Lift Lines.

The design factor for lift lines shall be determined using the following formula:

$$DF = \frac{(F_u \times RF)}{w} \quad \text{Where:}$$

F_u = the ultimate strength, or minimum load, in N [lb] at which tensile failure occurs, as certified by the manufacturer.

RF = The strength Reduction Factors that reduce the static load breaking strength. Strength reduction factors take into account bending as the lift line passes over sheaves, and the types of knots or fittings used. Refer to the current edition of the Wire Rope User's Guide, or to manufacturer's specific recommendations for appropriate strength reduction values.

w = Design Load: the maximum anticipated static load in Newtons (pounds) that the lift line will support in use.

8.4 Radial Bearing Pressure

Maximum radial bearing pressures shall not exceed the values defined in Table 2. Where sheave material is not specifically listed, values shall be obtained from the sheave manufacturer, and shall be included in the system manual.

Backstagesafety.org

TABLE 2 – Radial Bearing Pressure*

Suggested Allowable Radial Bearing Pressure of Ropes on Grooves in Various Sheave Materials Values shown in kilopascals (kPa) and [pounds per square inch (psi)]								
Material	Regular Lay Rope				Lang Lay Rope			Flattened Strand, Lang Lay
	6 x 7	6 x 19	6 x 37	8 x 19	6 x 7	6 x 19	6 x 37	
Cast Iron	2,068 [300]	3,309 [480]	4,033 [585]	4,688 [680]	2,413 [350]	3,792 [550]	4,551 [660]	5,516 [800]
Carbon Steel Casting	3,792 [550]	6,205 [900]	7,412 [1,075]	8,687 [1,260]	4,137 [600]	6,895 [1,000]	8,136 [1,180]	9,997 [1,450]
Chilled Cast Iron	4,482 [650]	7,584 [1,100]	9,136 [1,325]	10,687 [1,550]	4,930 [715]	8,343 [1,210]	9,997 [1,450]	12,273 [1,780]
Cast Polyamides*	13,790 [2,000]	13,790 [2,000]	13,790 [2,000]	13,790 [2,000]	13,790 [2,000]	13,790 [2,000]	13,790 [2,000]	13,790 [2,000]

Table 2 note: for 7 x 19 Galvanized Aircraft Cable or 7 x 19 Specialty Cord, use table values shown for Regular Lay Rope 6 x 19 (Table data is taken from the Wire Rope User Manual and other sources).

The unit radial bearing pressure on the sheave, at the groove contact surface, shall be determined using the following formula:

$$P = \frac{2T}{Dd} \text{ where:}$$

- P = Radial bearing pressure, in kPa (psi)
 T = Wire rope tension, in Newtons (pounds)
 D = Sheave tread diameter, in centimeters (inches)
 d = Wire rope nominal diameter, in centimeters (inches)

8.5 Sheave Bearing Ratings

The L10 rating for sheave bearing complements shall be based upon the following operational criteria:

- 8.5.1** Operational speed not less than 1.5 meters/sec (300 feet/minute);
8.5.2 Minimum lifespan rating of 2000 hours;
8.5.3 Radial load value of 1.25 times the block resultant load.

9 Basic functional and safety requirements

Manual counterweight rigging systems shall be designed, manufactured and installed to meet the basic functional and safety requirements described herein.

9.1 Edge protection

The walking/working surface of loading and operating bridges shall have OSHA-compliant railings and toe plates, or other OSHA-compliant edge protection.

9.1.2 Toe Plates

Toe plates shall extend from the walking/working surface to not less than 4" above the surface, or not less than the maximum height at which objects are intended to be stored, whichever is greater.

9.1.3 Exceptions*

Special exceptions shall be permitted when necessary for normal operation of the system.

9.1.3.1 Fixed railings shall not be required on the arbor access side of loading bridges, provided that other methods of edge protection or fall protection are provided to meet the intent of OSHA requirements regarding obstructions to competent worker access, and mitigation of the fall-from-height hazard.

9.1.3.2 Exceptions to railing height and midrail requirements shall be permitted when necessary for normal operation.

9.2 Operating system characteristics

9.2.1 Plumb operating lines

Operating lines shall be installed so that the upper and lower arbor attachment portion is plumb.

9.2.1.1 Non-plumb permitted

Non-plumb installation shall be permitted on the portion routing through the rope lock, but shall minimize operational friction, lateral loading and wear on the rope lock.

9.3 Loading system characteristics

All manual counterweight rigging systems, regardless of type or size, should have a loading bridge to facilitate loading and unloading of counterweights in a manner that prevents an unbalanced load suspension system. All new manual counterweight rigging systems, regardless of type or size, shall have a loading bridge to permit loading and unloading of counterweights in a manner that prevents an unbalanced load suspension system.

9.3.1 Proximity*

Loading bridges shall be in proximity to the arbors to permit loading and unloading of counterweights by an average-height person, standing or kneeling on the loading bridge walking surface.

9.3.2 Elevation

Loading bridges shall be located at an elevation to permit loading/unloading of the arbor when the batten is at low trim.

9.3.3 Multiple bridges permitted

Multiple loading bridges shall be permitted where arbor length prevents loading and unloading access to the entire arbor from a single bridge.

Figures

This section contains illustrative figures describing typical system layouts.

FIGURE 1 - Typical lineset

Overview:

reeve the rope line (10) the top of (6), reeves the head down the rope and the block (11), terminates point on bottom. creates a loop system. rope lift are also the top of and reeve head block (4), attached to (1) by the

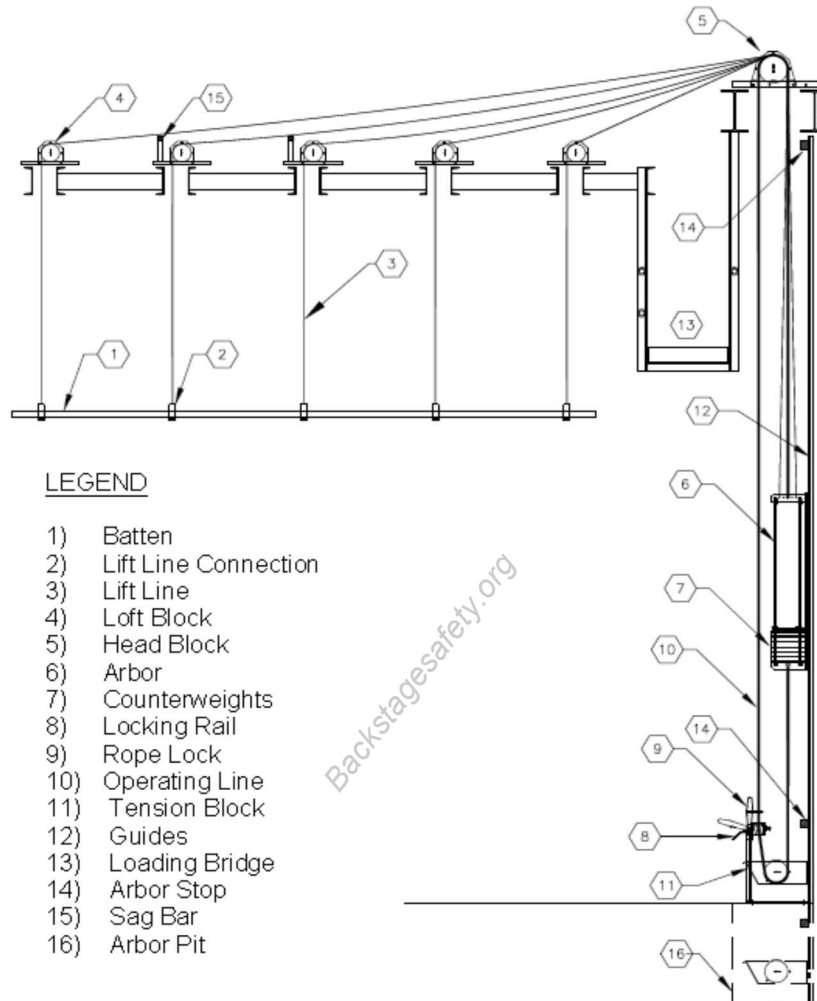

In a single system, operating attaches to the arbor up around block (5), through lock (9) tension and then to a tie-off the arbor. This closed-operating. The wire lines (3) attached to the arbor, over the and loft and are the batten lift line.

connections (2). Counterweights (7) counterbalance the batten loads (at a 1:1 load-to-counterweight ratio), and are loaded (unloaded) to the arbor from the loading bridge (13). Arbors are guided using rigid guide rails (12), or are wire-guided (not shown) in locations where the arbors must be located in open floor space, away from an adjacent support wall. An arbor pit* (16) may be used to increase the overall arbor travel distance. Component details are described in section 3.

Load suspension system: The load suspension system in a typical lineset consists of a batten (1), lift line connections (2), lift lines (3), loft blocks (4), a head block (5), an arbor (6) and counterweights (7). Together these components provide the load support and counterbalancing for the lineset.

Operating system: The operating system in a typical lineset includes the locking rail (8), the rope lock (9), the operating line (10) and the tension block (11). An arbor pit (16) may also be included when additional arbor travel space is necessary, or is desired to maximize the batten's overall travel limits.

Guide system: The guide system in a typical lineset includes the vertical guide components, which may be either rigid guide rails (12) or wire rope, and the method for attaching the arbor to those vertical guide

components. Even though the attachments are connected to the arbor, they are considered part of the guiding system, not the load suspension system.

FIGURE 2 - Typical double reeved lineset

The reeved

Overview:
double system

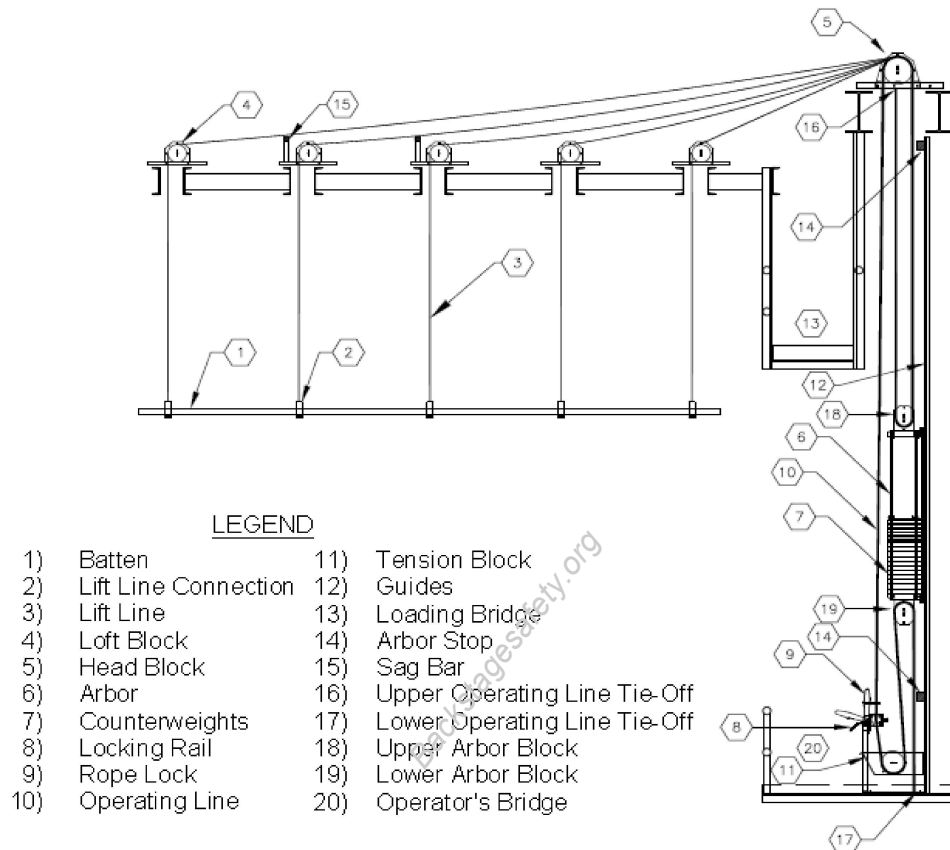

configuration differs slightly from the Single reeved typical lineset system (refer to Figure 1), in that the operating line and the lift lines are reeved through additional block assemblies at the top and bottom of the arbor. The operating line is attached to an upper attachment assembly (16) located below the head block. This assembly is either integral to the head block assembly, or directly attached to the head block structural support steel. The operating line then reeves down and around an upper arbor block (18), then back up around the head block, down through the rope lock, around the tension block, then reeves up and around a lower arbor block (19), then down to a lower termination point (17), located below the tension block. The lift lines also attach to the upper attachment assembly, and reeve down and around the upper arbor block, back up and over the head and loft block, then down to the batten termination points. This configuration requires a 2:1 ratio of counterweight to batten load. It does not provide a mechanical advantage, but it does provide an operational advantage by which the arbor travel distance is half of the batten travel distance. Component details are described in section 3.

The load suspension system, operating system and guide system components are identical to the typical lineset described in Figure 1.

FIGURE 3 - Typical Rope and sandbag Lineset

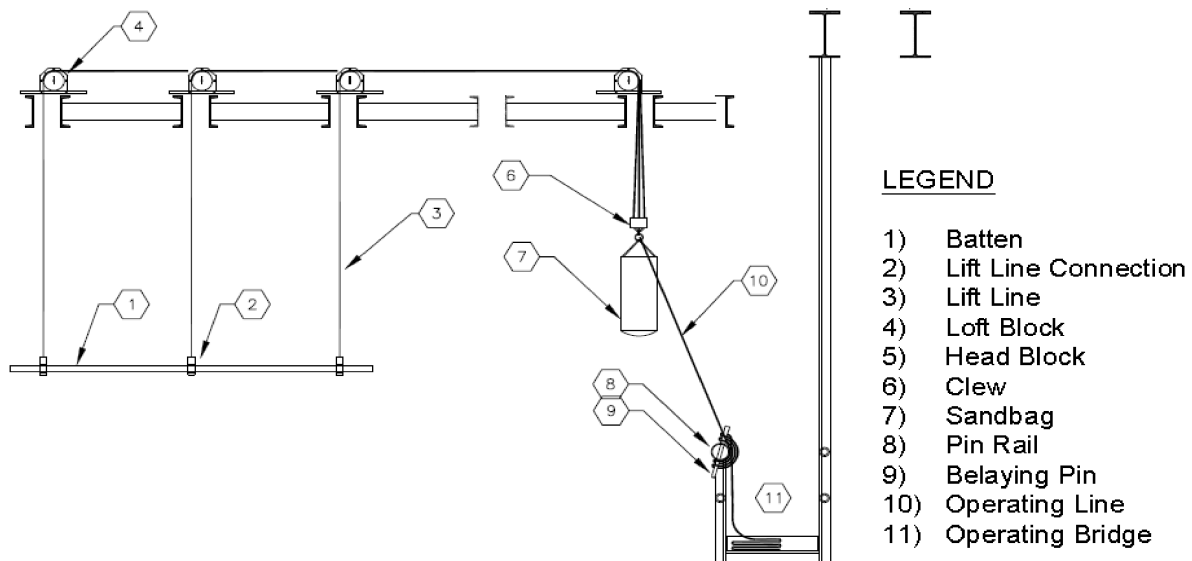

Overview: The typical rope and sandbag system uses natural-fiber or synthetic fiber rope lift lines instead of wire rope, and uses sandbags as the counterbalancing method. The lift lines (3) are tied off at the pin rail (8), are reeved up over the head block (5), and the loft blocks (4), then down to lift line connections (2) along the batten (1). The counterweight method uses sandbags (7), instead of arbors. Component details are described in section 3.

Load suspension system. The load suspension system in a typical lineset consists of a batten (1), lift line connections (2), lift lines (3), loft blocks (4), a head block (5), one or more sandbags (7) tied off to a pin rail (8). Together these components provide the load support and counterbalancing for the lineset.

Operating system: The operating system for rope and sandbag systems is usually the lift lines themselves, but sometimes a separate operating line (10) is used, attached to the lift lines using a clew (6). This is an example of an open-loop operating system.

Guide system: Rope and sandbag systems are typically not guided.

Annex A

This annex contains informative notes that are not part of the normative requirements of the standard.

A.3.1.4 Ductile materials

Since the general definition of ductile refers to a material's ability to be drawn out into a wire, the standard elaborates further by requiring plastic deformation. Another way to relate this concept is by comparison of the material's yield point to its ultimate tensile strength. Materials having non-ductile properties, and that do not deform plastically without fracturing have either a yield point very close to its ultimate tensile strength, or have no yield point value because the yield point is, essentially, equal to its ultimate tensile strength. Acceptable materials will give a clear indication of failure, by first deforming within its plastic range, before ultimate failure actually occurs. Generally speaking, using non-ductile material is not acceptable, but there are exceptions. Sheaves are commonly made of Gray Cast Iron, as are component items such as pillow block and bearing housings, used in applications where loads are primarily compressive rather than tensile.

A.3.1.5.2 Flat washers

The use of flat washers is also relevant to minimum torque values. Where no minimum torque values are specified, the use of flat washers is probably not important. Conversely, any time minimum torque values must be achieved, or in applications where slotted or elongated holes are part of the connection, consideration should be given to the use of hardened flat washers as part of the appropriate connection method.

A.3.1.7 Manufacturer's instructions

Throughout the document, references are made to following the manufacturer's recommendations when selecting, using, applying or installing certain components or assemblies. Manufacturer's recommendations may include printed instructions, recommended procedures, guidelines, or may even include specific requirements. It is always preferable to obtain and follow printed instructions from the manufacturer, where possible, as this allows for more complete documentation of procedures for any given application.

A.3.2.1 Typical batten

Typical battens are constructed of 1 1/2" nominal [48.3 mm] (1.9" actual O.D.) Schedule 40 steel pipes. While other sizes or shapes may meet or exceed the structural requirements of this section, it is important to recognize that many commonly available pipe and fixture clamps used to make load attachments to the batten are specifically made to accommodate a range of pipe sizes up to, but not exceeding, this size of pipe.

A.3.3.4.1 Trim chain assemblies

The typical trim chain assembly described provides a 2-part load path between the batten attachment and the lift line. The intent of the section is to require either a) manufacturer's certification that the chain is rated for overhead lifting, in accordance with NACM definitions, or b) manufacturer's certification that the chain is suitable for the intended application if its material properties and strength characteristics do not meet or exceed that of Grade 30 Proof Coil chain. As of the publication date of this standard, only Grade 80 or higher alloy chain is acceptable by the NACM for overhead lifting.

A.3.4.4.3 Manufacturer's instructions, and A.3.4.4.4 Wire rope termination methods

The installer or user of components and assemblies, such as terminations, fittings, fasteners, and components, has a responsibility to determine if these components are used as intended by the specific manufacturer of the component. Generally, such components will be easily identifiable, often by means of unique manufacturer markings that indicate the variety, type, style, or material composition of the component. Where such markings are not present, or where the manufacturer's recommended usage criteria are unclear, the manufacturer of the component should be consulted to verify that the intended use is acceptable.

A.3.4.4.5 Natural and synthetic fiber ropes termination methods

At a pin rail, the lifting lines are typically lashed to the belaying pins by looping the rope twice around the belaying pin above and below the pin rail in a figure-8 pattern, with the free rope end tucked under the final loop at the top of the pin rail. For normal operation, this accomplishes a secure termination that can be easily undone.

A.3.5.1.3 Line retention

Blocks should contain a method to ensure that the rope remains in the sheave's groove. This method can be accomplished by using spacers, or other specially designed accessories.

A.3.5.1.7.2 Drilling

Torque values for threaded connections vary based upon the materials, type of connection, and the predominant forces to which the connection is subjected (e.g. tensile, shear, etc.). Often, a connection will not require a specified torque value, while in some cases a minimum torque value is critical in order to achieve and maintain the full connection strength. Each type of connection and application should be evaluated by a licensed professional engineer in order to determine a) if a minimum torque value is applicable, b) if applicable the actual torque value or range, and c) the correct method for obtaining the specified torque, where required.

A.3.5.1.4.4 Mounting clips

Beam clips are typically bent with a short right angle, or can have welded to them a piece of round or flat stock. These shimming methods serve to minimize bending of the clip when the mounting bolts are tightened. Ideally, the tightened bolts will be perpendicular to the clamped materials, but in practice this is frequently not the case. Thus, the toe (or shim) also serves to maintain the perpendicularity between the bolt and the clamped material by limiting the amount of deflection that can occur. In doing so, this also helps maintain the contact surfaces between the bolt head, the nut, and the clamped materials.

A.3.7.3 Standardized configuration

This section describes a typical, industry standardized arbor configuration.

A.3.8 Counterweights

Lead is classified as a hazardous material in some jurisdictions, and is therefore not recommended for use as a counterweight material.

Poor control of the materials used in iron castings in the past resulted in some particularly brittle counterweights that broke during the rough handling and then could no longer be properly secured in the arbors. Materials used for counterweights that are to be handled in normal use should be made of materials that can withstand abuse without breaking.

A.3.8.1 Size and shape requirements

Ergonomics are an important consideration when determining the maximum weight that can be safely managed in a given work environment.

A.3.9 Compensating systems

Load imbalances are particularly inherent to systems having extremely long arbor travel distances, in which the self-weight of the wire rope creates a load shift such that the normal out-of-balance condition becomes excessive. Compensating systems help to reduce the overall net imbalance by transferring a load equivalent to the weight of the wire rope to the batten side or the arbor side of the head block as the arbor moves through its normal range of travel. A compensating system should reduce the overall net imbalance in the system to within the maximum allowable out-of-balance condition.

As the arbor is raised, the system load imbalance shifts from the arbor side to the batten side. At the same time, the compensating load shifts onto the arbor, minimizing the out-of-balance condition. Conversely, as the arbor is lowered, the load shift on both the lineset and the compensating system is reversed.

The typical compensating load is determined by the net system load imbalance (per lineset), divided by the overall travel distance. For example, if a lineset has a 60-foot travel, and a 60-pound net load imbalance at the arbor travel extents, the compensating load required would be 60 pounds/60 feet = 1 pound per foot of travel.

A.4.4.2 Minimum rope diameter

Operating lines are sized for handling efficiency and are not sized for strength. The minimum size requirement represents accepted industry standard based on a rope size that can be effectively, efficiently and ergonomically gripped.

A.4.5 Operating line tensioning methods

Operating systems for manual counterweight linesets are typically closed-loop, meaning that the operating line is terminated in a manner that connects the counterweight arbor as part of a loop. These systems need a method for minimizing operating line slack, usually accomplished with a tension block mounted below the arbor, to the floor or to the arbor guide rails. Rope and sand bag systems are not endless loop operating systems, and therefore do not require tensioning methods because gravity inherently eliminates slack from the operating system.

A.4.6.1 Arbor stops

Stop battens are intended to prevent metal-to-metal contact of surfaces, to minimize operational noise due to such contact, and to minimize impact loads occurring as an ancillary result of normal operating conditions. Stop battens are not intended to prevent structural damage in the event of unanticipated shock loads, nor are they intended to stop uncontrolled movement (such as a runaway arbor), because such conditions are not normal to proper operation of the system.

A.4.6.2 Guide wire stops

Arbor stops on wire-guided systems are intended as a visual indication of arbor location only. Imparting additional loads to the wire guides and terminations is not recommended. Therefore any style of stop that attaches to wire guides should slip under load.

A.6 System documentation, labeling and marking

Head blocks or head beams should be labeled with the permanent name or number of their respective corresponding line sets as shown on the lock rail. Such marking can improve ease of system operation, inspection and maintenance.

A.6.3 Locking rail labeling and signage

Head blocks should be labeled to correspond with their respective lineset numbering, so that they can be accurately correlated for inspection purposes.

A.6.8 Block labels

The requirements of this section do not preclude additional equipment labeling as may be specified by the system's designer or as applied by the system owner or users after system installation, repair, modification, or inspection. Such additional labeling, intended to enhance safety, operational convenience, or as an aid to future inspections, may include lineset number labels on rigging blocks, adjacent railings or building structure, dimensional spacing or load limit marking on battens, stage centerline marks, etc.

A.6.10 Manuals

Users of the system should read and thoroughly understand the information contained in the system manual. Knowledge of the system-specific load capacities, operating instructions, and maintenance schedules are important to establishing safe operating practices.

A.7.2 General requirements

Additional inspection requirements may include proof testing of specific linesets, or of the entire system. A qualified person should determine the extent of such additional testing requirements, and the method of execution.

A.9.1.3 Exceptions.

Loading bridge rails, locking rails and pin rails often require alternative spacings and heights to accommodate normal operation. OSHA 29 CFR 1926.501 (b) (2) permits exceptions to railing requirements in circumstances where compliant railing systems interfere with normal access and operation, or where compliant railings create

hazard due to the operational requirements of the equipment. Since the general industry requirements of 29 CFR 1910 are not specific enough to address the special considerations of manual counterweight systems, 29 CFR 1926 is referenced here instead.

A.Table 1, Item #2 – minimum sheave diameter

A commonly accepted value used to determine minimum sheave diameter for wire rope is a D:d ratio of 28:1, where 'D' is the root diameter of the sheave, relative to 'd' (the nominal diameter) of the wire rope. However, manufacturers may specify other minimum acceptable values. In all cases, a larger D:d ratio will both increase wire rope life (by minimizing wear due to bending factors) and will also reduce operational noise.

A.Table 2 – Radial Bearing (Groove) Pressure

Current industry terminology can cause confusion about radial bearing pressure, and to what it actually applies. Table 2 refers to the unit pressure between the wire rope and the sheave groove. However, the term "Radial Bearing Pressure" is also commonly used in sheave design, as a reference to the unit pressure on the sheave bore, at the outer race of the shaft support bearing(s). Particularly with cast polyamide sheave materials, the load-bearing characteristics differ notably between a turned (solid, machined-groove) sheave and an injection-molded sheave. This difference exists primarily because an injection-molded sheave typically uses molded support ribs to distribute loads across a thinner cross-sectional area, from the groove surface into the bore. Conversely, a machined sheave typically has a consistent and thicker cross-section from the groove into the bore, and therefore transfers the loads more efficiently. For accurate sheave design, manufacturers must consider the specific material properties relative to both groove pressure, and to bore pressure.

A.Table 2 – Cast Polyamides

Cast polyamide is a generic term used as a reference for any one of several materials, all in the nylon polyamide family of thermoplastics. These materials are available from a wide range of manufacturers, which usually specialize in special purpose, or high-strength sheaves. Although these materials are in the same family, they can differ in material properties, so the specific manufacturer of the material should be consulted for accurate material property values for the purpose of radial bearing pressure calculations. Thus, a separate value is given for cast polyamides, primarily because the load-bearing characteristics between injection-molded polyamide, and cast polyamide sheave designs are notably different. The values shown in Table 2 are for general use only, and based upon minimum loads above which the pressure of the cable acting upon the sheave over a period of time will temporarily deform the sheave.

A.9.3.1 Proximity

The ideal working elevation of a loading bridge is dictated by a combination of arbor length and the location of its top arbor stop. In practice, a minimum of one bridge should be required if the arbor is short enough that its entire live load length is accessible from one working elevation. However, frequently arbors are long enough that they cannot be accessed from a single elevation, so it becomes beneficial to have more than one loading bridge. The second bridge should be at least 10' below the second, but factors such as the length of the arbor and height of the proscenium may require a different spacing. Railings on the side adjacent to the counterweight system require special consideration to accommodate the practicalities of the loading/unloading process. Often, railings need the maximum allowable spacing, and/or may need to be removable to safely accommodate arbor loading and unloading.

A.Figure 1, item 13

Arbor pits are often used to allow a longer arbor travel in circumstances where the overall line set travel may be adversely limited by extremely tall arbor sizes. Where pits are used, they should be designed to facilitate inspection and maintenance operations. For arbor pits that adjoin habitable space below the stage area, and that have a depth greater than 1.5m (5 ft.) below the stage elevation, separate access doors should be provided that permit access to the pit area at the pit floor elevation. Pit access doors should be lockable from the adjoining area side(s), but should also be fully operable from the pit area side.

As a precautionary measure, pit access doors should have signage attached to the exterior that clearly states: "**DANGER! Moving Equipment Inside! Authorized Personnel Only!**"